

Technical data

Pump name 3D 65-160/11

Customer	Date 23-June-2020	Company
Contact	Item no.	Issued by
Phone	Project	Phone
E-mail	Project ID	E-mail

Requested data

1	Pump type	CENTRIFUGAL PUMP	Fluid	Water, clean
2	Number of pumps / Reserve	1 / 0	Liquid temperature	K 293
3	Flow	m ³ /h 0	Kin. viscosity	mm ² /s 1
4	Head	m 0	Vapour pressure	kPa 2.2
5	Geodetic head	m 0	PH value	7
6	Inlet pressure (pin)	kPa 10	Density	kg/m ³ 1000
7	Available system NPSH	0	Solids	Weight % 0
8	Ambient temperature	K 290		

Pump

9	Pump name	3D 65-160/11	Frequency	Hz 50
10	Design	CENTRIFUGAL PUMP	Installation type	STANDARD
11	Manufacturer	EPE	Impeller Diameter	Max. mm 168
12	Speed	1/min 2900		Designed mm 168
13	No. of Stage	1		Min. mm 168
14	Connection	Suction side EN 1092-2	Flow	Operating m ³ /h
15	Connection	Discharge side EN 1092-2		Max- m ³ /h 138
16	Max Working Pressure	kPa 1000		Min- m ³ /h 42
17	Shut-off head	kPa 396.68	Head	Operating m
18	Total weight	kg See the table of "Dimensions".		- (Qmax.) m 19.9
19	Shaft power	kW		- (Qmin.) m 39.0
20			Max. Shaft Power at max. impeller	kW 11.08
21	Required pump NPSH	m	Efficiency	%

Materials

22	Impeller	AISI 316		
23	Casing	Cast iron		
24	Shaft	AISI 304 (wet extension)		
25				
26				
27				

Motor

28	Manufacturer	EPE Standard	Insulation class	F
29	Type	TEFC_3D 65-160/11_400_Three Phase	Phases	3~
30	Specific design	IE3 / 50 Hz / Pole pairs 1	Frame size	
31	Rated power	kW 11	Weight	kg 0
32	Number of poles	2	Electric voltage	V 400
33	Speed	1/min 2900	Electric current	A 21.3
34	Degree of protection	IP 55		
35				

Remarks

--

Performance curve Pump name 3D 65-160/11

Customer	Date 23-June-2020	Company
Contact	Item no.	Issued by
Phone	Project	Phone
E-mail	Project ID	E-mail

Requested data

1	Flow	m ³ /h	0
2	Head	m	0
3	Geodetic head	m	0

Pump

Operating Flow	m ³ /h	Frequency	Hz	50
Operating Head	m	Number of poles	2	
Impeller Diameter	Designed mm	168	Speed	1/min

Test standard: ISO 9906:2012 - Grade3B

Water, clean [100%] ; 293K; 998.3kg/m³; 1mm²/s

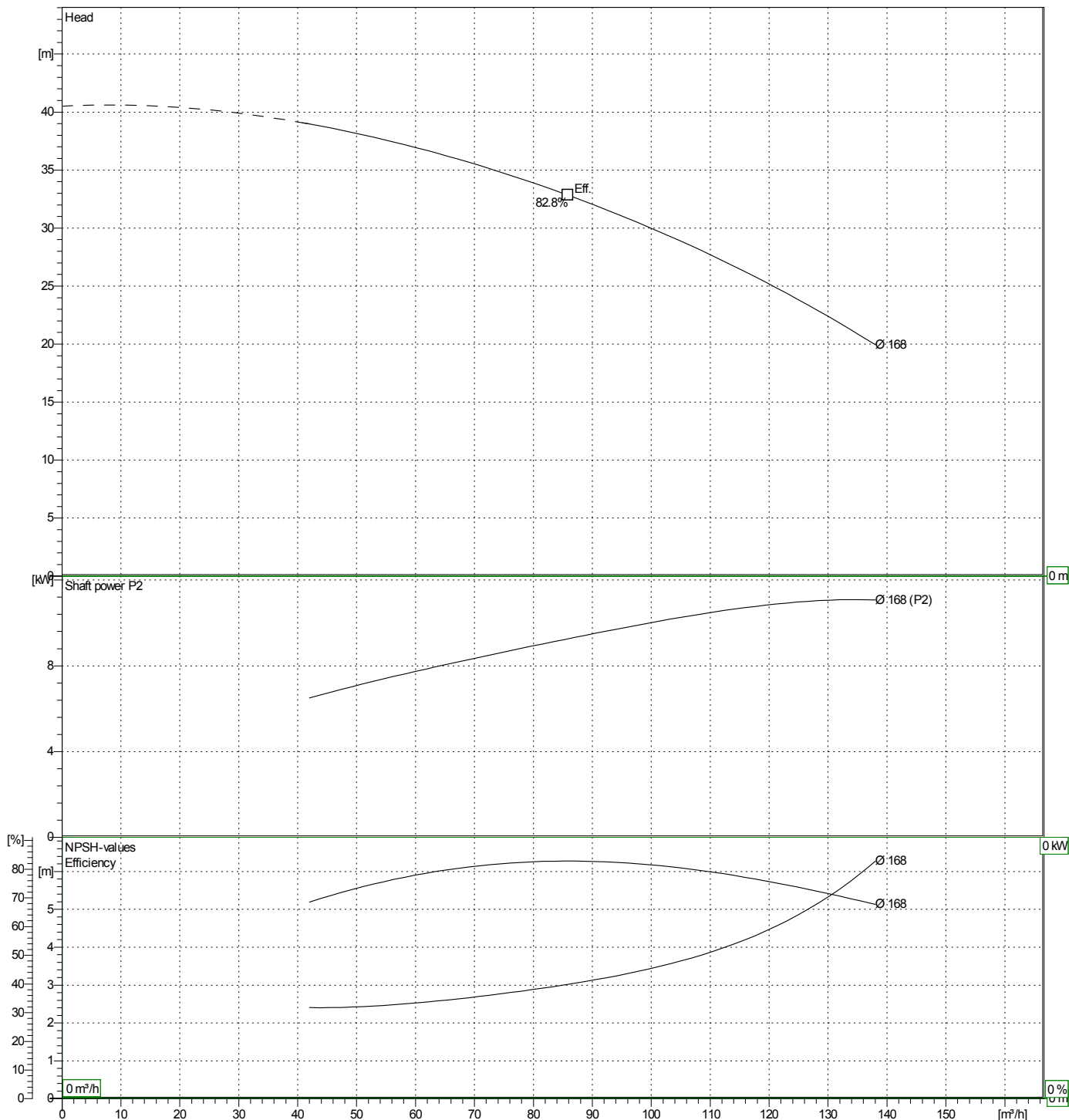

Dimensions

Pump name 3D 65-160/11

Customer	Date 23-June-2020	Company
Contact	Item no.	Issued by
Phone	Project	Phone
E-mail	Project ID	E-mail

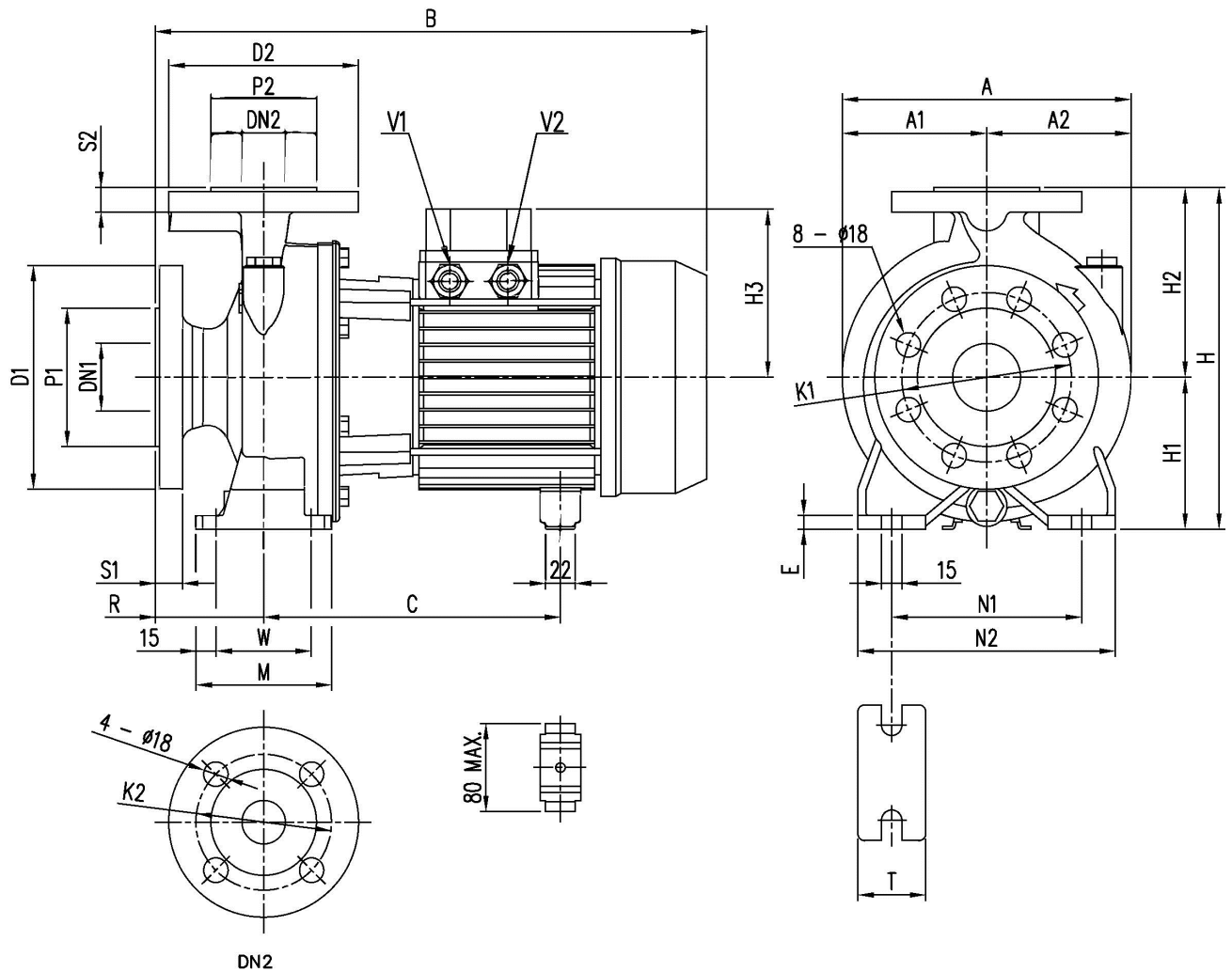

Dimensions in		mm					
1	A	296	E	12	V2	PG 21	
2	A1	148	H	360	W	95	
3	A2	148	H1	160	Weight P&M	87.4 kg	
4	B	595	H2	200			
5	C	359	H3	178			
6	Dia D1	200	M	125			
7	Dia D2	185	N1	212			
8	Dia DN1	80	N2	280			
9	Dia DN2	65	R	100			
10	Dia K1	160	S1	22			
11	Dia K2	145	S2	20			
12	Dia P1	138	T	65			
13	Dia P2	122	V1	PG 13,5			

(1/3) Construction

Pump name 3D 65-160/11

Customer	Date 23-June-2020	Company
Contact	Item no.	Issued by
Phone	Project	Phone
E-mail	Project ID	E-mail

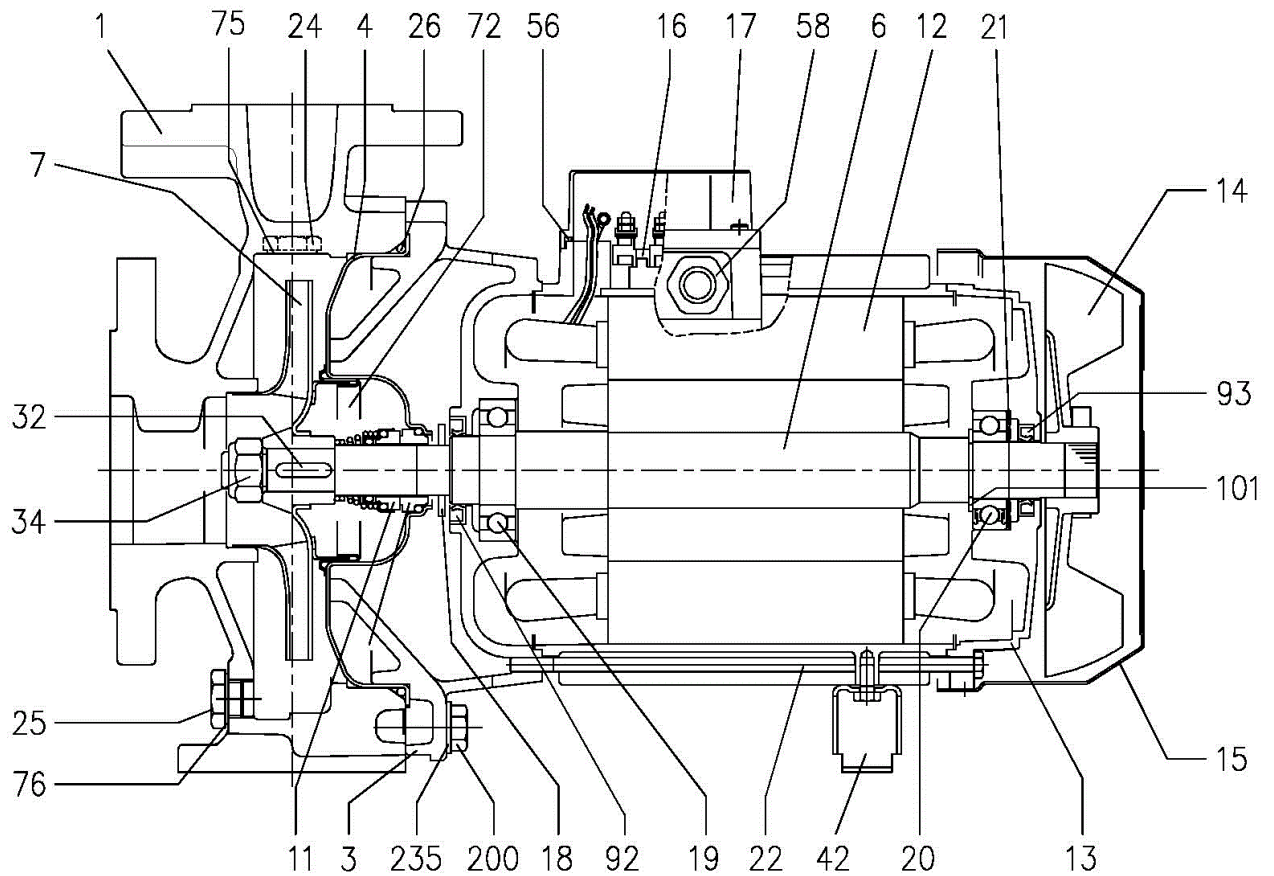

(2/3) Construction

Pump name 3D 65-160/11

Customer	Date 23-June-2020	Company
Contact	Item no.	Issued by
Phone	Project	Phone
E-mail	Project ID	E-mail

N°	PART NAME	MATERIAL	DIMENSIONS	STANDARD	Q.TY
1	Casing	Cast iron EN-GJL-250-EN 1561			1
3	Motor bracket	[1]			1
4	Casing cover	EN 1.4301 (AISI 304)			1
6	Shaft with rotor - Wet extension	EN 1.4301 (AISI 304)			1
7	Impeller	[2]			1
11	Mechanical seal	[3]			1
12	Motor frame with stator	-			1
13	Motor cover	Aluminium			1
14	Fan	PA			1
15	Fan cover	Fe P04 Galvanized			1
16	Terminal	-			1
17	Terminal box cover	Aluminium (three phase version)			1
18	Splash ring Up to 11 kW	NBR	40x21.5x2	EBARA DRAWING	1
19	Bearing	[10]			1
20	Bearing	[10]			1
21	Adjusting ring	Steel C70			1
22	Tie rod Up to 3 kW For 4 - 5.5 - 7.5 kW 9.2 e 11 kW	Fe 42 Galvanized	M5	EBARA DRAWING	4
			M6		
			M8		
24	Priming plug	Brass	G 3/8" L=8		1
25	Draing plug	Brass	G 3/8" L=8		1
26	O-ring 32-125, 40-125 32-160, 40-160, 50-125, 65-125 32-200, 40-200, 50-160, 50-200/9.2, 50-200/11, 65-160/7.5, 65-160/9.2, 65-160/11	NBR/FPM/EPDM	158.11x5.34	OR 6625	1
			183.52x5.34	OR 6720	
			227.96x5.34	OR 6895	
32	Key Up to 11 kW	EN 1.4401 (AISI 316)	A 6x6x25	UNI 6604	1
34	Impeller nut Up to 11 kW	EN 1.4301 (AISI 304)	M16x1.5	UNI 7474	1
42	Foot	Aluminium / Galvanized steel		EBARA DRAWING	1
56	Box gasket	NBR			1
58	Cable gland	-			1
72	Casing ring	[5] EN 1.4301 (AISI 304)			1
75	Washer	Aluminium	22x17x1.5	EBARA DRAWING	1
76	Washer	Aluminium			1
92	Lip seal Up to 3 kW From 4 to 7.5 kW From 9.2 kW to 11 kW	-	25x40x7	DIN 3760 without spring	1
			30x47X7		
			40x55x7		
93	Lip seal Up to 4 kW From 5.5 kW to 7.5 kW From 9.2 kW to 11 kW	-	25x40x7	DIN 3760 without spring	1
			30x47X7		
			40x55x7		
101	Snap ring	[6] Carbon tool steels TC 80	Ø 40	UNI 7435	1
200	Screw 32-125, 40-125 32-160, 40-160, 50-125, 65-125 32-200, 40-200, 50-160, 50-200/9.2, 50-200/11, 65-160/7.5, 65-160/9.2, 65-160/11	Gv. Steel 8.8 strenght class ISO 898-1	M 8x30	UNI 5739	8
			M 10x35		10
					12
235	Washer 32-125, 40-125 32-160, 40-160, 50-125, 65-125 32-200, 40-200, 50-160, 50-200/9.2, 50-200/11, 65-160/7.5, 65-160/9.2, 65-160/11	Galvanized Steel	8.4x17	UNI 6592	8
			10.5x21		10
					12

- [1] Cast iron EN-GJL-200-EN 1561 for 3D 32-200/3
Aluminum AL-EN-1706-AC-46000-D for all the others
- [2] EN 1.4301 (AISI 304) for 32, 40, 50 series
EN 1.4401 (AISI 316) for 65 series
- [3] See **CONSTRUCTION 3**
- [4] See **CONSTRUCTION 3**, "O-ring" column
- [5] Only for: 32-200, 40-200, 50-160, 50-200/9.2, 50-200/11
- [6] Only for pumps with 9.2 and 11 kW motor

(3/3) Construction

Pump name 3D 65-160/11

Customer	Date 23-June-2020	Company
Contact	Item no.	Issued by
Phone	Project	Phone
E-mail	Project ID	E-mail

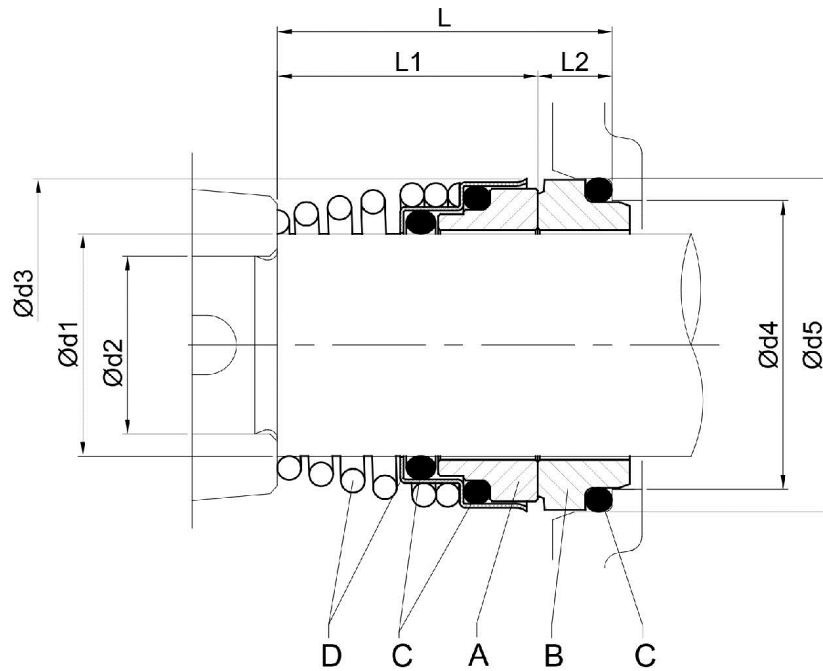

Pump type	Dimensions [mm]									Material Standard			
	d1	d2	d3	d4	d5	L	L1	L2	A Rotary seal ring	B Stationary seal ring	C O-ring	D Frame + Spring	
32-125/160/200													
40-125/160/200													
50-125/160/200	22	19	38	31	37	37.5	27.5	10	Ceramic	Carbon	NBR	EN 1.4301 (AISI 304)	
65-125													
65-160/7.5-9.2-11													